

TECHNOLOGY TO THE POINT



SMART
TECHNOLOGY



FLEXIBLE
INTEGRATION



SUSTAINABLE
SOLUTIONS

Haitian Plastics Machinery Group Co., Ltd
No.1688, Haitian Road, Xiaogang, Beilun, Ningbo, Zhejiang, China 315801
+ 86-574-8617 7005 (China)
+ 86-574-8617 7242 (International)
haitian@mail.haitian.com
www.haitianpm.com

NINGBO HAITIAN HUAYUAN MACHINERY CO.,LTD.
No.1, Nanhuan Road, Export Processing Zone, Beilun, Ningbo, Zhejiang, China 315806
+86-574-8617 7242
+86-574-8622 1864
haitian@mail.haitian.com
www.haitianpm.com



MARS SERIES

SERVO-HYDRAULIC SOLUTION
600 - 12,000 kN



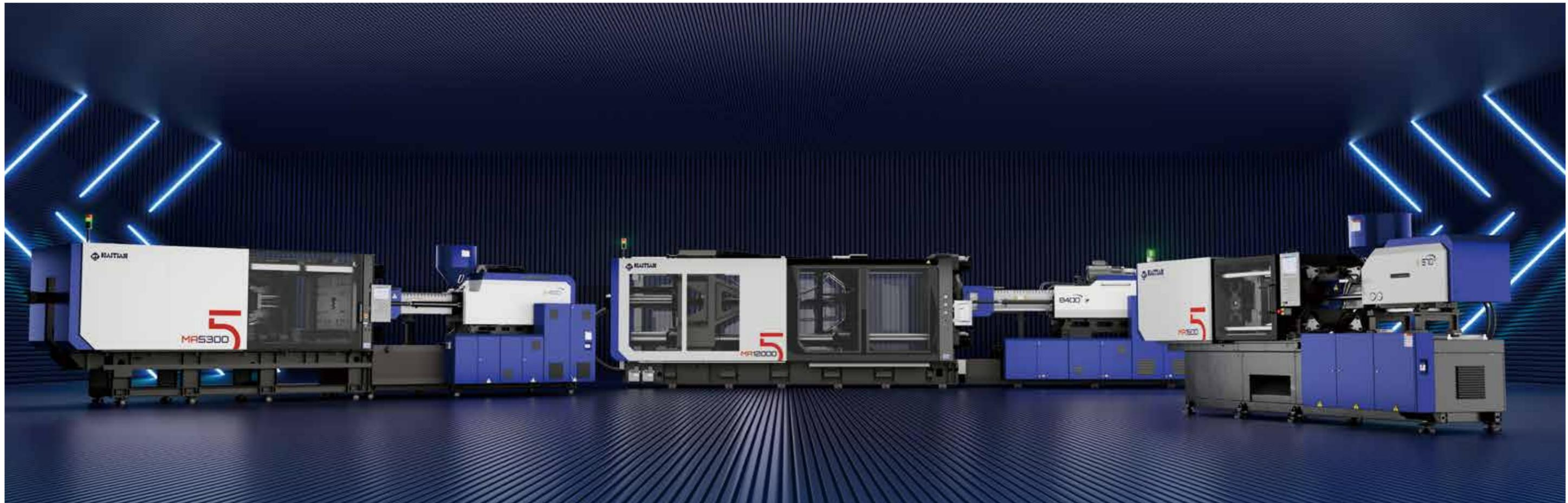

TECHNOLOGY TO THE POINT



SMART
TECHNOLOGY



FLEXIBLE
INTEGRATION



SUSTAINABLE
SOLUTIONS

Opening up the future of the fifth generation

Continuous optimization of quality and efficiency, new digital intelligence and the development of sustainable solutions are important keys of future-oriented plastics machinery industry. Haitian International works tirelessly to meet customers' needs by continuously improving its core technology platform and driving innovation at the highest level. The fifth generation creates a new intelligent manufacturing format that enables injection molding machines, mold-, application and one-stop solutions and once again sets the benchmark for the injection molding machine industry.

Smart

Smart Technology

In the modern technological landscape, smartness not only stands for the edge, but also for success. At "Haitian smart & intelligent products", we have continuously evolved to give mechanical hardware "a soul engine" through digital intelligence platforms. AI algorithms and sensor technology enable intelligent optimization of production processes and provide self-awareness, self-adaptation, self-decision-making and self-reconfiguration of smart equipment. Our new fifth machine generation sets new standards. With a clear focus on smart innovation and enablement, we strive to minimize operating costs and maximize production efficiency. Our vision: Shaping a smart future together with our customers.

Flexible

Flexible Integration

Our intelligent injection molding machines are equipped with flexible and open integration functions. Open interfaces support efficient connection with peripheral devices, automation units, etc. With the upstream and downstream data of the industrial value chain, an integrative production ecosystem is created that generates extensive information benefits for the plastics processor. From plant status and production plan to process control and quality traceability to full life cycle management incl. energy consumption, decision analysis, etc., the result is an integrated production ecosystem.

Sustainable

Sustainable Solutions

As an industry leader, Haitian International Haitian International focuses its research and development efforts on fulfilling social responsibility, protecting the environment, and conserving and utilizing resources. We continue to develop energy-saving and consumption-reducing technologies, promote the upgrade and iteration of energy-saving drives, reduce the carbon footprint of equipment, and provide technological innovation and efficient solutions for the use of degradable and recyclable materials. We remain customer-focused with application-driven solutions made by Haitian. Technology to the point for economic and environmental benefits and a future fit for next --generations.

MA 5 SERVO-HYDRAULIC SOLUTIONS

Energy-saving, efficient, intelligent

Relying on the fifth generation technology and inheriting the excellent genes of the world's best-selling servo hydraulic energy-saving injection molding technology, MA5 was launched. The full range of performance breakthroughs and advancements, from injection to plastification and mold clamping structures, are optimized and improved in every aspect. The hardware configuration continues to evolve and bring new appearance upgrades, setting industry benchmarks for performance and quality, and easily coping with future

technical challenges. At the same time, it is equipped with multiple smart technologies, which can fully meet customers' personalized and flexible production requirements while improving efficiency. The newly upgraded electric charging device, combined with the latest energy-saving technology and information technology, makes the injection molding process more energy-saving and efficient, creating a new intelligent injection molding ecology.

20-40% Electrical charging with higher energy saving rate

Energy Saving 

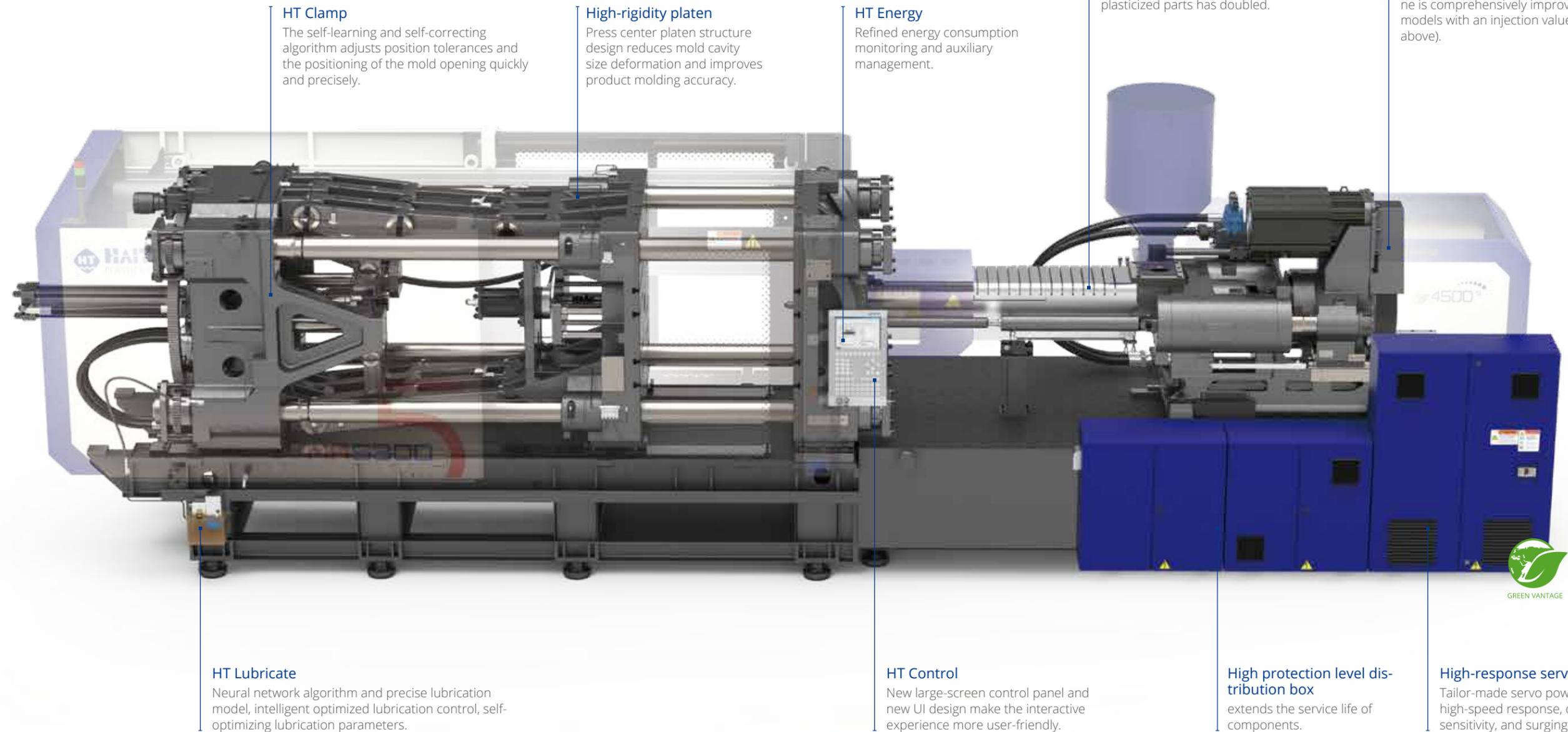

HT Clamp

The self-learning and self-correcting algorithm adjusts position tolerances and the positioning of the mold opening quickly and precisely.

High-rigidity platen

Press center platen structure design reduces mold cavity size deformation and improves product molding accuracy.

HT Energy

Refined energy consumption monitoring and auxiliary management.

Upgraded plasticizing unit

The plasticizing performance has been greatly improved, and the wear resistance of plasticized parts has doubled.

Electrical charging

The plasticizing speed and quality are improved, while the energy efficiency of the entire machine is comprehensively improved (optional for models with an injection value of 10600 and above).

HT Lubricate

Neural network algorithm and precise lubrication model, intelligent optimized lubrication control, self-optimizing lubrication parameters.

HT Control

New large-screen control panel and new UI design make the interactive experience more user-friendly.

High protection level distribution box

extends the service life of components.

High-response servo system

Tailor-made servo power system, high-speed response, dynamic sensitivity, and surging power.



MA 5 CLAMPING UNIT



High-rigidity platen structure

The fixed platen and clamping rear platen structures are optimized to increase rigidity and reduce deformation.

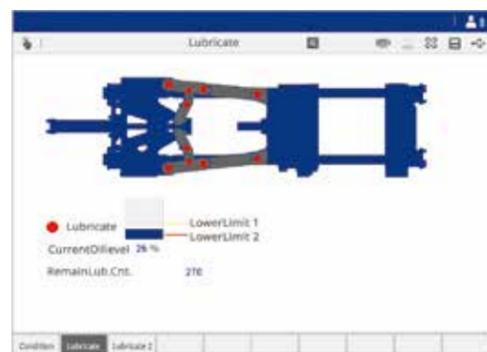
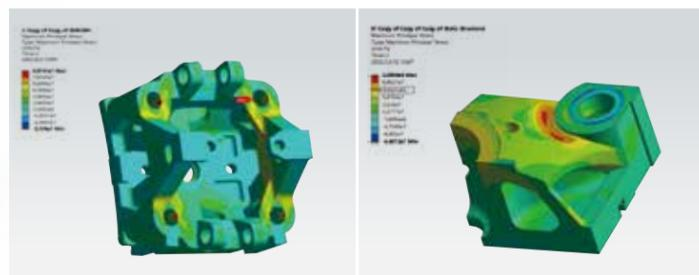

HT Lubricate

Based on extensive industry experience, the digital lubrication model uses a neural network to dynamically regulate the ideal amount of lubrication.

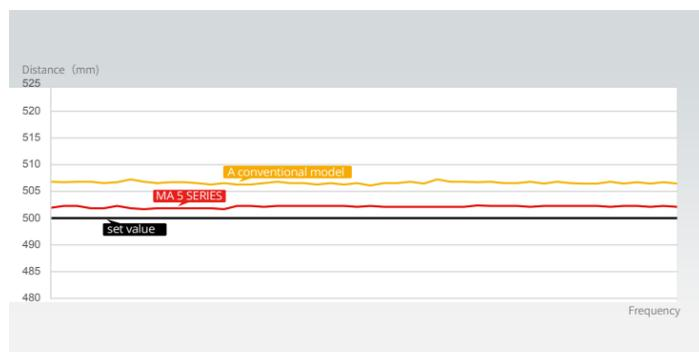

HT Clamp

Self-learning and self-correction algorithm corrects position deviation, accurate mold opening and positioning, and provides a stable and fast movements.

T-slots as standard

All platens are equipped with T-slots as standard, which enables convenient handling.

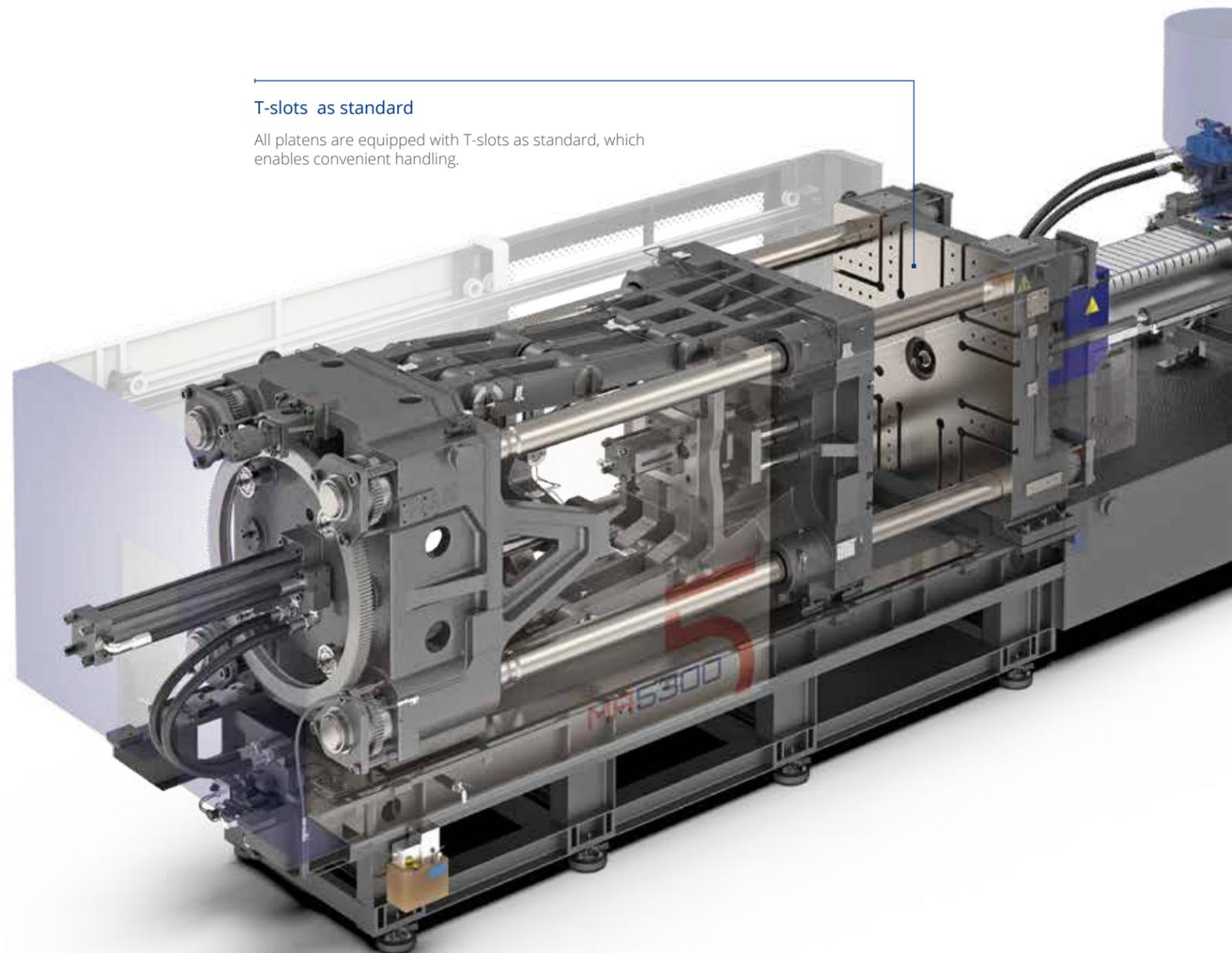

MA 5 INJECTION UNIT

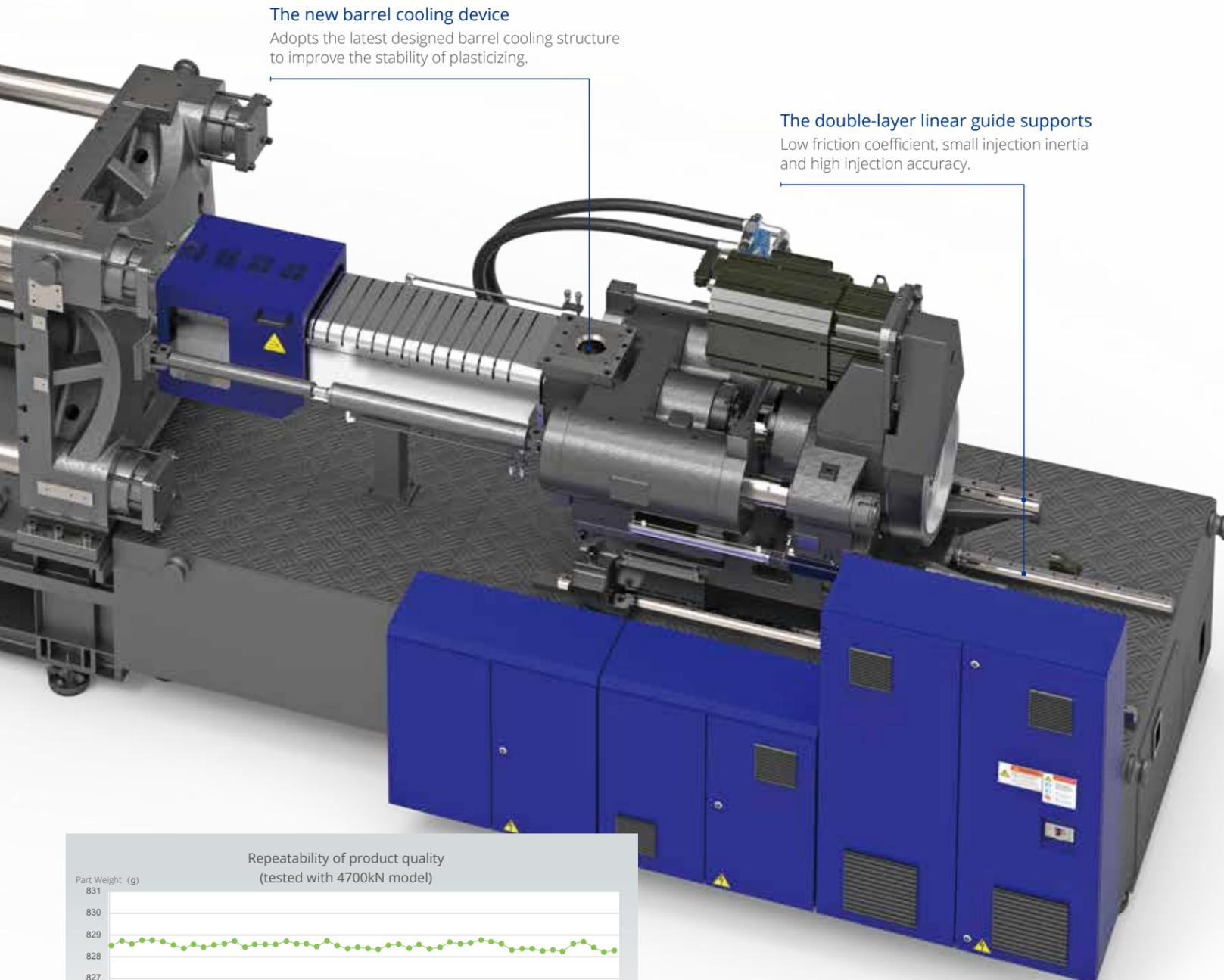

The new barrel cooling device
Adopts the latest designed barrel cooling structure to improve the stability of plasticizing.

The double-layer linear guide supports
Low friction coefficient, small injection inertia and high injection accuracy.

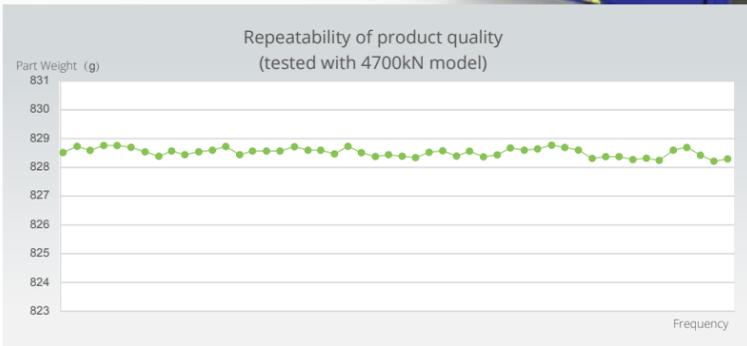

Full closed-loop injection control
For precise injection movement, fast response, repeatability in injection, good low speed stability and good product consistency. It improves the performance of the equipment and the adaptability of the process.

20-40% Electrical charging with higher energy saving rate

Energy Saving



Electrical charging
The new electric pre-molding not only improves the plasticizing speed and quality, but also improves the energy efficiency of the whole machine.



Overall upgrade of plastication unit
The plasticized parts have been comprehensively upgraded, and the plasticizing performance has been greatly improved. The wear resistance of the plasticized parts has doubled, and the service life has been extended.



Energy-saving insulation device
The energy-saving insulation device adopts a double-layer barrel cover structure and a detachable energy-saving insulation structure design, which effectively improves the heating and insulation effect.

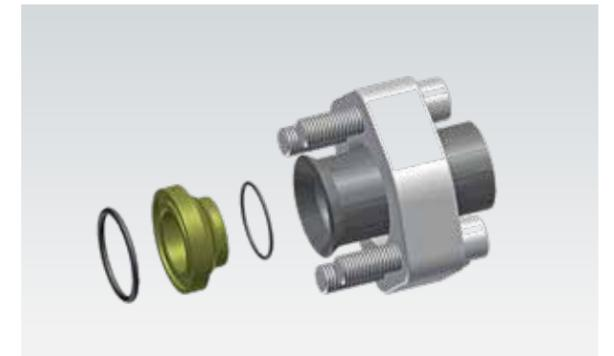

Non-welding power pipelines
The non-welding process of power pipelines reduces the risk of oil leakage, improves the cleanliness of pipelines, and extends the service life of hydraulic components.

MA 5 POWER SYSTEMS

The fifth generation dedicated servo power system for injection molding machines

Haitian continues to be committed to the field of servo drive and control systems. A long and vast application experience makes it possible for us to develop a new generation of servo drive systems equipped with high performance servo drives and the latest high speed gear pumps from Japan Sumitomo. The result: efficient and energy-saving, high performance, quiet and stable operation.

Ultra-high dynamic response

Easily matches customers' needs for high-speed and high-response equipment and expands the scope of product processes.

Ultra-low speed and high stability

Adopt dynamic differential compensation technology to completely solve the internal leakage problem of the gear pump and easily meet customer requirements for ultra-low speed and high stability.



Fifth generation injection molding machine dedicated tailor made servo motor



The fifth-generation dedicated servo drive for injection molding machines

Fully digital bus control system with high dynamics and high responsiveness.



Latest high speed gear pump for injection molding from Sumitomo Japan

The new QS pump has ultra-high stability and greatly improves work efficiency.

MA 5 CONTROL SYSTEM

6,000 kN and below models

- 12.1-inch TFT LCD display, 800x600 resolution, part of the display program is independently controlled by Cortex A8 processor
- Partitioned full-function keyboard, including page navigation, data entry, operating mode, status transition and action buttons
- Series online help interface functions, QR code link online help function
- Multi-language online switching, complete multi-language text display



7,000 kN and above models

- 15.6-inch touch screen, vertical layout, richer human-computer interaction information, more reasonable partitions, and more friendly multi-touch operation
- Standard RFID user identification card reader
- Standard 4 groups of 8 online configurable add-ons buttons
- Standard configuration of 16 channels of extended programmable button input
- Series of online help interface functions, QR code link online help function
- Can support PDF, 3D view file display
- New screen collection function, quickly locate commonly used screens
- Multi-language online switching, perfect multi-language text display



HT·XTEND SMART FEATURES AS GENERAL STANDARD

HT Clamp



HT Diagnose



HT Clamp Force



HT Dosing



HT Energy



HT Lubricate,
HT Inspect
HT Alert



Mars has never been more process-optimized. The intelligent functions we have developed are "in line" with the development of our entire series. For example, HT Energy, in which we have dispensed with conventional sensor technology and instead implied a mathematical model. This solution was also developed

in-house, in close cooperation with other Haitian divisions, and is available to users as standard equipment, at no extra cost. Because our principle still applies: We want to give our customers the greatest possible competitive advantages without imposing additional costs on them.



HT Clamp

Self-learning and self-correction algorithm adjusts position deviation, accurates mold opening and positioning, and stables and fast movement.



HT Lubricate

Digital lubrication model, combined with neural network control, dynamically matches the optimal lubrication amount.



HT Clamp

The intelligent clamping force system model algorithm simulates the actual and real clamping force. Setting and display is in standard.



HT Dosing

Charging speed adaptive control optimize energy consumption and reduce mechanism wear.



HT Energy

Standard with refined monitoring of energy consumption, auxiliary management, statistics and analysis of energy consumption distribution in the production process. Provides decision-making basis for the energy optimization strategies in your manufacturing.

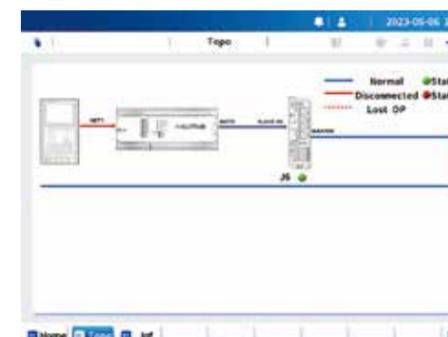
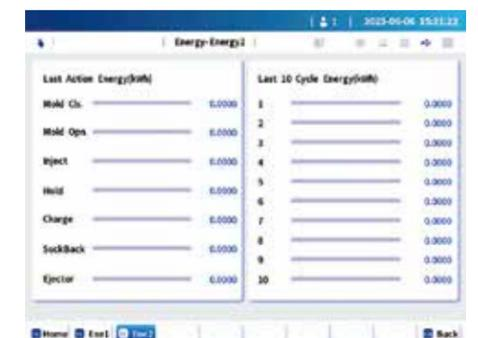

HT Diagnose

The graphical digital bus topology provides information on the status of the most important control units, thus helping the operator for maintenance to quickly locate faulty nodes and determine the cause of the fault.

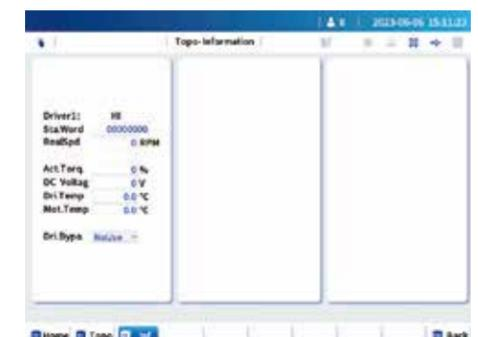

MA 5

FLEXIBLE INTEGRATION

MA5 is equipped with flexible open integration functions, and the entire series is equipped with "Go Factory 2.0" digital intelligent management software, which can best meet customers' one-stop demands for automated and digitally intelligent production.

In addition, it can be compatible with the latest international general interfaces according to needs. Customers can freely choose automation integration equipment and MES partners to realize interactive connections between multi-device and multi-platform systems with injection molding machines as the core, and enjoy open integration.



MA 5 CONFIGURATION

Injection unit

- Single-cylinder injection system for models of 2500kN and below,
- Dual-cylinder injection system for models of 2800kN and above
- Nozzle centering fine adjustment device
- ESG injection function (4700kN and below models)
- Linear guide rail for injection and carriage
- Electrical charging device (12000kN and below)
- Energy-saving insulation cover for barrel (12000kN and below models)
- Barrel heating temperature closed-loop control (applicable to both K-type and J-type)
- Screw cold start prevention function
- Injection curve monitoring function, memory function
- Injection fully closed-loop function
- HT Dosing function
- V/P switching (position, time, pressure OPT)
- Three seating and withdrawal methods (after material charging, before mold opening, after injection)
- Back pressure control of charging proportion
- Automatic purging function
- Secondary charging function
- Servo control hydraulic system
- Oil temperature detection and alarm function
- Bypass filtration system (2500kN and below models)
- Independent filtration system (2800kN and above models)
- Removable oil suction and oil filter device (2500kN and above models)
- Energy-saving control of oil cooling water valve
- HT Energy

Clamping unit

- Three-plate clamping unit
- Low pressure mold protection
- High rigid moving platen supports sliding feet
- Ejector rod inverted structure
- Standard with Haitian standard T-slot + threaded hole template

- Robot mounting threaded hole interface (EUROMAP 18)
- Automatic mold adjustment function
- HT Clamp
- HT Lubricate
- HT Clamp Force
- Electrical and hydraulic double chain insurance
- Adjustable back and top stroke
- Three hydraulic ejection methods (vibration, holding, multiple times)
- Ejection delay function
- Controllable ejector program
- Optional moving/fix platen hydraulic core
- Free core function
- Optional moving/fix platen cooling water interface

Optional features

- The clamping unit matches the size of the injection unit
- Charging during mold opening
- Electrical charging (injection volumn 10600 and above models)
- Hydraulic (pneumatic) nozzle
- Injection servo closed-loop control
- Injection direction proportional control
- Proportional control of mold opening and closing direction
- Closed-loop temperature control at feed opening
- Mold hot runner control
- Pneumatic cores
- Function of multiple-set cores
- Glass tube flow meter
- Valve gate (pneumatic/hydraulic)
- Robot electrical and mechanical interface
- Magnetic template electrical interface
- OPC DA/OPC UA data interface
- Mold positioning ring
- Tie bar extraction function
- Hydraulic clamp
- Side automation equipmen
- Integrated energy-saving dryer
- Conveyor belt

- Standard
- Optional

MA 5 OPTIONAL FEATURES



HT Smart peripherals

Machines can be equipped with smart peripherals to realize the side automation.

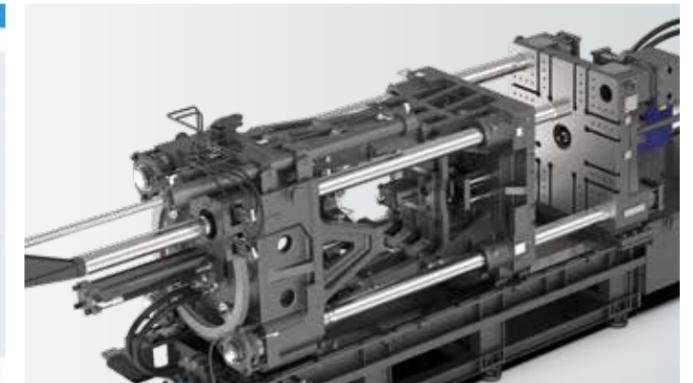

Tie bar extraction function

This device facilitates mold installation and removal, which is flexible with different mold types, and has a small footprint in terms of height.

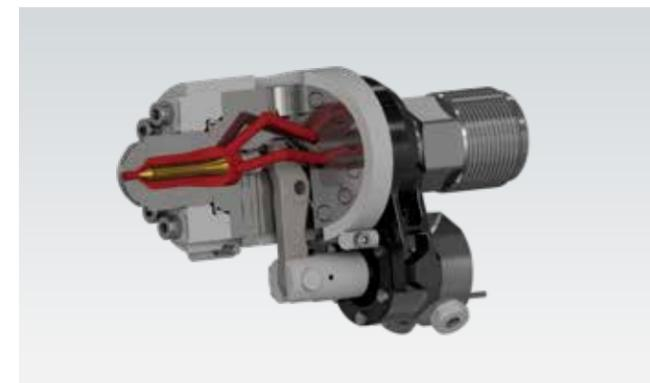

Hydraulic nozzle

For uniform plastic distribution and filling during the injection molding process to enhance quality.



Proportional control

For a fast and high-precision mold opening and closing.



Glass tube flow meter

For simple and intuitive display of the cooling water level; the flow and pressure of the cooling water can be adjusted to actual needs.



Extended interfaces

For e.g. hot runners, cores, sequence valve and others.

MA 5

EXAMPLES FOR FIELDS OF APPLICATION



● Automobile industry

The automotive sector is versatile and the industry is growing rapidly. Our approach: cost-efficient system solutions for flexible and fully automated smart production lines.



● Appliance industry

The consumer goods market is the mass market for plastic products par excellence and is more competitive than any other. Standard applications in production – albeit with sometimes high quality requirements.



● Consumer electronics industry

Our everyday life is rich in technical systems such as cell phones, tablets, computers or memory cards and connectors. New slim designs, new surfaces and innovative functions and short product cycles requires competitive solutions.



● Logistics industry

The large dimensions and volumes of the parts quickly shift the focus to material consumption and processing. This requires well thought-out, cost efficient manufacturing solutions if you want to survive in the face of tough competition.

HAITIAN WORLDWIDE



1

Overseas Management Center

6

Regional Headquarters

5

Manufacturing Center

9

Application & Experience Center

- Management HQ
- Overseas Management Center
- Regional Headquarters
- Manufacturing Center
- Application & Experience Center